

XIII. *On the Adaptation of different Modes of Illuminating Lighthouses; as depending on their Situations and the Object contemplated in their Erection.* By WILLIAM HENRY BARLOW, Esq. *In a Letter addressed to PETER BARLOW, Esq., F.R.S. &c., and communicated by Him.*

Received April 27,—Read May 4, 1837.

Constantinople, March 14th, 1837.

HAVING made several experiments with the DRUMMOND light, and other means of illuminating light-houses, undertaken at the request of the Turkish Government, with a view to placing lights at the entrance of the Bosphorus from the Black Sea, I have been led to observe some facts regarding the illuminating powers of the lights themselves, and the increase obtained by the use of reflectors and lenses, which, I trust, may not be found uninteresting.

On the increase of illuminating power obtained by Lenses and Reflectors.

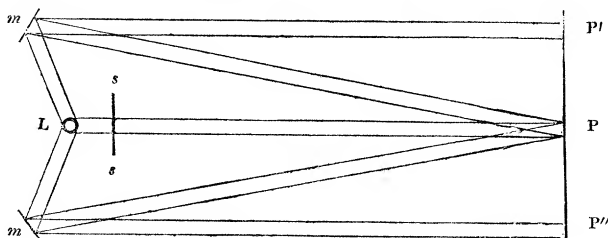

Let L in the annexed figure represent a lamp; *m, m*, two reflectors, which may be so adjusted as to throw the reflected images either in parallel lines on a screen at P' and P'', or at such an inclination as to unite with that of the light itself at the centre point P. Let also *s s* represent a screen of such imperfect transparency as to absorb the same quantity of light in transmission as the mirrors *m, m* absorb by reflection; then in the first case the three images P', P, P'' will have equal surfaces and intensities*, and the illuminating power will be three times that of the central lamp; and when by a different adjustment of the mirrors the three images are blended in one, then the surface will be equal to that of the central image, but the intensity three times greater, so that in either case the illuminating power will be proportional to the number of mirrors, or to the surface of those mirrors. If, therefore, we conceive the whole space between *m, m* to be filled with mirrors, to reflect the light in parallel lines on the screen P', P, P'', it is clear that the illuminating power of the

* We reject here the difference in the length of the trajectory of the direct and reflected light.

lens will be expressed by the number of times the surface of the central image is contained in the whole surface of the screen P' , P'' ; and this is true whether we consider the several images to be thrown in parallel lines, or condensed in a focus, or dispersed over a larger surface, for as the illuminated surface is contracted, the intensity is increased, and as it is extended, the intensity is diminished in the same proportion, so that under all circumstances the product of surface and intensity will be a constant quantity. Hence the illuminating power (abstracting from absorption) will be increased by the reflector in the ratio of the surface of the lights to the surface of the end or section of the reflector. Or in other words, the area of the end of the reflector divided by the area of the light, will be a numerical measure of the illuminating power.

This result is obtained by supposing the reflector to be composed of a number of small plane reflectors, each throwing the light in parallel lines, and each image therefore as having the same intensity as the direct light (screened as above) when viewed from the same distance; but with a continuous curve surface, such as a parabolic reflector, we must consider the divergency of the emanating ray at the point where it falls on the reflector, which will vary inversely as the square of the distance of that point from the centre of the light, or directly as the square of the sine of half the angle which the light subtends from that point, and therefore as the versed sine of half the same angle; and the sum of all these must be compared with the area of the reflector, that is of its section or end, which varies also as the versed sine of half the angle which its extreme edge subtends at the light.

In order, therefore, to compute the increase of illuminating power due to a parabolic reflector, according to this principle, we must find a *mean focal distance*, that is, a distance (from which to estimate the constant angle subtended by the light) that shall be equivalent to the several variable distances.

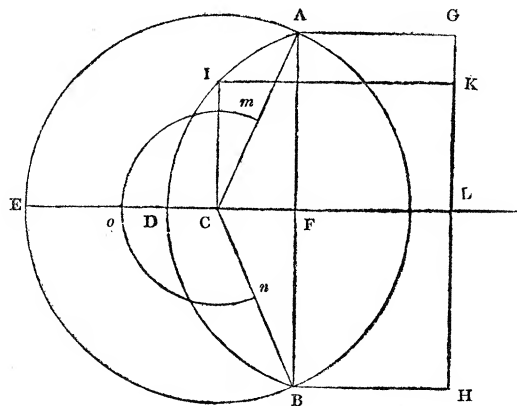

Let $A D B$ be a parabolic reflector and C its focus, then will $D C$ be the minimum and $A C$ the maximum focal distance. Now if the light at C emanated from a point, all the rays intercepted by the surface $A D B$ would be projected forward in parallel lines and cover the plane surface $G H = A B$ at whatever distance it might be placed

from the reflector, and the light at G, K, L would be that due to the distances AC, IC, DC respectively: if then a segment of a sphere *mon* be described intercepting the same number of rays as ADB, and whose surface is equal to the area of AB or HG, we shall have the same quantity of light equally distributed over the same surface; hence the radius of the segment *mon* will be the mean focal distance with which all the light may be conceived to leave the reflector.

Describe the circle AEB; then, because ADB is a parabola, and AEB a circle described about it with the radius CA, and because CA = DF + DC, the height DF of the parabola = $\frac{1}{2}$ the height EF of the segment AEB.

But EF = EC + CF = AC + CF, therefore DF = $\frac{AC + CF}{2}$,

and DC the minimum focal distance = DF - CF = $\frac{AC - CF}{2}$. Let AC = *r*,

CF = *h*, then *r* = maximum focal distance, and $\frac{r-h}{2}$ = minimum focal distance, $(2r \times 3.1416)(r+h)$ = surface of segment AFB; and $4(r^2 - h^2) \cdot 7854$ = area of AB or GH.

Let *x* = radius of segment *mon*: now the surface of the segment AEB is to the surface of the segment *mon* as r^2 to x^2 , and the area of the end AB is equal to the surface of the segment *mon*, therefore

$$(2r \times 3.14161)(r+h) : 4(r^2 - h^2) \cdot 7854 :: r^2 : x^2$$

or

$$2r(r+h)x^2 = (r^2 - h^2)r^2$$

whence

$$x^2 = \frac{(r^2 - h^2)}{2r(r+h)} r^2 = \left(\frac{r-h}{2}\right)r$$

or

$$x = \sqrt{r \left(\frac{r-h}{2}\right)}$$

But *r* = maximum focal distance and $\frac{r-h}{2}$ minimum focal distance. Therefore *x*, the mean focal distance, is a mean proportional between the maximum and minimum focal distances. Let therefore A represent the angle subtended by the reflector from the centre of the light, and *a* = the angle subtended by the light from the reflector at the mean focal distance, then

$$\frac{\text{versed sine } \frac{1}{2} A}{\text{versed sine } \frac{1}{2} a}$$

will be the amount of illuminating power obtained by the reflector, that of the lamp being 1.

This result differs in its numerical value very little from the former, viz. the area of the reflector divided by the area of the light. Thus, for example, let a reflector whose maximum focal distance is twelve inches, and minimum three inches, be illu-

minated with a standard ARGAND lamp, the diameter of the *flame* of which is one inch, and its altitude $1\frac{3}{4}$ inch. Here the depth of reflector is 9 inches and the area of its end $4(12^2 - 6^2) \cdot 7854 = 339\cdot28$ inches. And by the first rule $\frac{339\cdot28}{1\cdot75} = 193\cdot8$ is the amount of power obtained.

By the second rule we have the angle subtended by the reflector equal 240° ; mean focal distance $= \sqrt{12 \times 3} = 6$ inches. The angle subtended by the flame of an ARGAND lamp, which is in the form of a cylinder, will be greater in the vertical direction than in the horizontal; in order therefore that we may be able to measure the surface of the segment by its versed sine, we will assume that the light is in the form of a sphere whose apparent surface and intensity is equal to that of the lamp, and therefore equal to it in illuminating power.

Now the angle subtended by a sphere whose apparent surface is 1.75 at a distance of 6 inches is $14^\circ 18'$; therefore by the second rule $\frac{\text{vers. } 120^\circ}{\text{vers. } 7^\circ 9'} = 192\cdot9$ amount of illuminating power obtained.

Let us now suppose DRUMMOND'S lime ball to be placed in the focus to find its illuminating effect. Here the section of the ball, the diameter being $\frac{3}{8}$ ths of an inch, is .110445, and on the first principle

$$\frac{339\cdot28}{\cdot110445} = 3079 \text{ amount of power,}$$

and by the second

$$\frac{\text{vers. } 120^\circ}{\text{vers. } 1^\circ 47' 27''} = 3071 \text{ amount of power*}.$$

And as it is known that the illuminating power of the lime ball when $\frac{3}{8}$ ths of an inch in diameter is equal to 16.6 ARGAND lamps, it follows that a reflector of the above dimensions will give a light equal to $3079 \times 16\cdot6 = 51112$ ARGAND lamps, or 264 such reflectors illuminated with ARGAND lamps; which agrees with DRUMMOND'S observations †.

These rules are equally applicable to lenses, the same effect being produced in them by refraction as in the reflectors by reflection, except the difference between the light absorbed and transmitted.

It is, however, almost impossible here to determine the mean focal distance very exactly, the lens being built in pieces; and its form being square increases the difficulty; still if we take the mean between the distance of the focal point from the

* It may not be seen immediately why these rules do not give precisely the same numerical results, but it will be found that if the angle of divergence be very great, the position of the reflector will at the extreme edge have a considerable obliquity to the line of direction in which it acts and its apparent surface, and consequently its illuminating powers will be reduced. The difference, however, is very small when the mean divergence is under 20° .

† Phil. Trans. 1830, p. 390.

centre and extreme angle of the lens, in the middle of the thickness of the glass, we obtain a tolerably close approximation.

Also, the lens being square, and eight of them forming the circle or system of lenses, $2 \left(\frac{\sin 22^\circ 30'}{8} \right)$ will be the expression for the light intercepted.

For example, let it be required to find the increase of illuminating power obtained by the French lens with its lamp, as used by DRUMMOND in his experiments, the lens being 30 inches square, and the lamp having an intensity equal to 4, and illuminating power equal to 10.4 ARGAND lamps.

Here the surface of the flame will be 4.55 inches; therefore by the first rule $\frac{30^2}{4.55} = 198$ increase of power. Again, the mean focal distance being about 39 inches, a sphere whose apparent surface is 4.55 inches will subtend $3^\circ 31'$; hence by the second rule

$$\frac{\frac{1}{4} \sin 22^\circ 30'}{\text{vers. } 1^\circ 45' 30''} = 200.$$

These examples being sufficient for the purpose of illustration, we may now state the conclusion which is derived from the above investigation; namely, that all reflectors and lenses of the same diameter have the same illuminating power when illuminated with the same lamp, and that decreasing the focal distance, and intercepting more rays, does not increase the illuminating power, but simply the divergence, and consequently the surface or space over which it acts.

On the Comparison of Lenses and Reflectors in reference to their Perfection as Optical Instruments.

The results obtained by the above rules, as to the actual increase of illuminating power produced by the use of reflectors and lenses, will of course be considerably greater than would be found in practice, no account being taken of the absorption, obstruction, or undue dispersion of the light; still, however, by comparing their computed powers with those obtained by experiment, we shall be enabled to ascertain their merits as optical instruments.

The French lens with its lamp was found by experiment to be equal to 9.1 reflectors 21 inches diameter, illuminated with Argand lamps*.

Now by computation (the lens being 30 inches square) and the intensity of its lamp 4, give $30^2 \times 4 = 3600$ for its illuminating power.

And a reflector 21 inches diameter, with a lamp whose intensity is 1, gives 346 illuminating power.

Therefore the illuminating power of the lens ought to be equal to $\frac{3600}{346} = 10.4$ reflectors.

* Philosophical Transactions, 1830, p. 383.

But we can hardly expect the lens to be so perfect an instrument as the reflector, not only from the obstruction of light caused by the zones, but from its being composed of separate pieces of glass, each of which has its own focus, which foci will coincide more or less according to the accuracy with which the instrument is made; and it is doubtless from the want of mathematical exactness in the adjustment and curvature of the pieces of which it is composed, that a small surface of light, such as the lime ball, is observed to produce but little effect when placed in its focus, and that the observed divergence of the lens is greater than the computed.

Taking the diameter of the lamp at 3 inches, the maximum horizontal divergence would be 5° , whereas in a revolution of 8 minutes the observed duration of the light was 7 seconds, making the observed angle of divergence $5^\circ 15'$.

In the reflector the duration was 25 seconds, which gives the observed divergence $18^\circ 45'$, while the computed divergence is $19^\circ 10'$, the computed in this instrument exceeding the observed.

Yet as eight lenses may be applied to one light, as well as some additional apparatus which increases their illuminating power, it possesses an advantage in point of economy when applied to a lighthouse; for with a lamp, consuming the oil of fifteen or sixteen ARGAND burners, we are enabled to illuminate eight times $5^\circ 15'$ or 42° of the horizon, the full power of the light being (with the additional apparatus) equal to 10.4 reflectors 21 inches diameter; while a reflector frame, such as that at Beechy Head, consumes the oil of thirty burners to illuminate three times $18^\circ 45'$ or $56^\circ 15'$ of the horizon, the full power of the light being equal to ten reflectors; whence it appears that the lenses illuminate three fourths of the number of degrees in the horizon which the reflectors do with the consumption of one half of the oil.

But although the sum of the angles of maximum divergence of the eight sides of a system of lenses is equal to three fourths of the sum of the angles of maximum divergence of the three sides of a reflector frame in the horizontal direction, yet the vertical divergence of the reflectors is far greater than that of the lenses.

The following are the maximum horizontal and vertical divergences of the reflector and lens.

	Max. Hor. Div.	Max. Vert. Div.
Reflector	$18^\circ 45'$	$31^\circ 54'$
French lens	5 15	3 0

The computed vertical divergence is less than this, but the observed horizontal divergence being found more than the computed, the 3° above stated would probably be found sufficiently correct in practice.

Hence it appears that the advantage gained by the use of lenses over that of reflectors, is not dependent upon their greater perfection as optical instruments, but from their using the light more economically, by reason of their having less divergence both horizontally and vertically, and illuminating much less space in the horizon.

ON DIVERGENCES.

The actual quantity of divergence necessary in any case is a question of considerable importance. As regards that in the horizontal direction, we have only to consider the practical question of the proportion of light to darkness in a revolution of the light frame. Thus, for example, three faces, each illuminating 16° of the horizon, and revolving in 8 minutes, would produce the same effect as six faces, each illuminating 8° , and revolving in 16 minutes. The decision will then be made by reference to the divergence in the vertical direction, the value of which will depend upon the situation of the lighthouse; for if the vertical divergence be too small, a ship might under peculiar circumstances be so near the lighthouse as not to catch the light at all, being, in fact, under the lowest rays; whereas should the situation of the lighthouse be such that a vessel never can approach within two or three miles of it, it is useless to throw away light upon a part where it can never be wanted; bearing in mind however that the refraction which now and then takes place might, in the event of the divergence being too small, prevent a vessel on the horizon from seeing the light, even were she at a proper distance to be able to discern it in the natural state of the atmosphere: some little excess therefore of the practical above the computed angle is requisite.

The following Table shows the vertical divergence required in lighthouses from 100 to 500 feet above the level of the sea, the distance at which the light is first required to be seen being from half to four miles from the lighthouse.

Height of Lighthouse in feet.	Distance at which the light is first required to be seen.				
	$\frac{1}{2}$ Mile.	1 Mile.	2 Miles.	3 Miles.	4 Miles.
100	$4^{\circ} 20'$	$2^{\circ} 12'$	$1^{\circ} 7'$	$0^{\circ} 46'$	$0^{\circ} 36'$
200	$8 40$	$4 22$	$2 12$	$1 30$	$1 10$
300	$12 58$	$6 32$	$3 18$	$2 14$	$1 42$
400	$17 14$	$8 42$	$4 22$	$2 56$	$2 14$
500	$20 28$	$10 50$	$5 28$	$3 40$	$2 46$

The axis of the instrument being supposed to be horizontal, the vertical divergence given in the table is twice the angle formed between the horizontal line and a line drawn from the light to the sea at the distance stated at the head of each column. Thus supposing a lighthouse 300 feet above the level of the sea, and that a vessel could not approach within four miles of it, we should only require $1^\circ 42'$ vertical divergence; but should a light of that height be so situated that a vessel might pass within one mile of it, we should require $6^\circ 32'$. Under which latter circumstances it is clear that the French lens having only 3° could not be made use of.

Hitherto, however, we have only spoken of the maximum divergences, without considering the minimum; but this is far too important a part of the subject to be overlooked, as it is only within the range or angle of minimum divergence that we can see the whole light of the reflector.

As regards the vertical divergences, if the maximum be sufficient for the situation of the lighthouse, the minimum will in most cases be enough to admit of a vessel approaching so near that some diminution in the power of the light will not be felt; and for this reason it is unnecessary to enter very minutely into this part of the question; we shall proceed therefore at once to notice the action of reflectors and lenses in reference to their horizontal divergences.

If we examine the effect of a reflector as it revolves on its frame, when seen from a distance of several miles (that is to say at such a distance that lines drawn from either side of the reflector to the eye may be considered as parallel) it will be found that it first begins to give its assistance when the eye is in the line $A C$, which is the extreme of the angle of maximum divergence, or when the angle formed between the line of the axis $C E$ and a line drawn from the eye to the reflector is equal to half the angle subtended by the light in its focus at the minimum focal distance $C F$, and the reflected light will first appear at C .

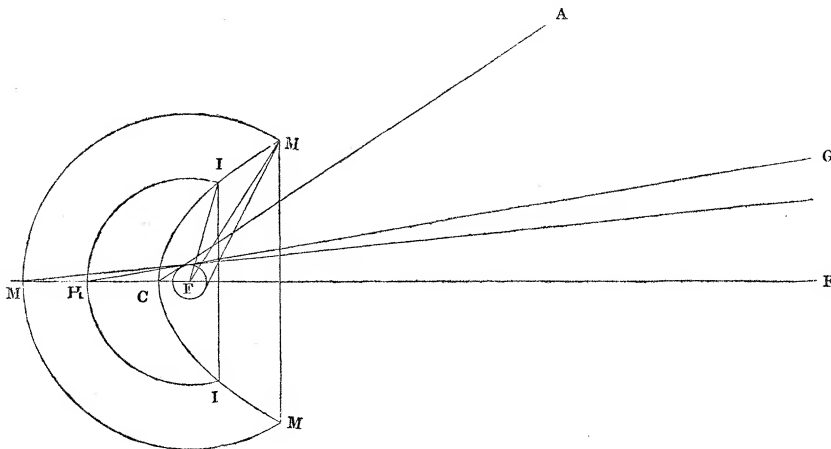

As the reflector continues its revolution the eye is brought into the line $G H$; $G H E$ being the angle formed between a line drawn from the eye to the reflector and the line of its axis, and $F H$ will be the distance at which the light would subtend that angle: now here the reflected light will have extended itself from C along the surface of the reflector to that part where its distance from the focal point is equal to $H F$. With $H F$ describe the arc $I H I$, then $I C I$ is the part of the reflector acting at that time, and the area of the circle of which $I I$ is the diameter multiplied into the intensity of the light will be the illuminating power at that time.

In the same manner the illuminating power will continue to increase until the angle formed between the axis of the reflector and a line drawn from it to the eye is equal to half the angle subtended by the light in the focus, at the maximum focal distance $F M$, when it will have attained its full power, at which it will continue until, by the revolution of the reflector, the same angle is formed on the other side of the axis, that is to say, the light will have its full power only during the range of the angle of minimum divergence, when it will begin to diminish; the reflected light receding from the edges of the reflector, and ceasing at the apex C .

But in a parabolic reflector the area of the circles $A a' A$, $B b' B$, $C c' C$, &c. are to each other as $\overline{A a'}^2$, $\overline{B b'}^2$, $\overline{C c'}^2$, &c., or as $D a'$, $D b'$, $D c'$, &c., or as their equals $A a$, $B b$, $C c$. Let $D F A$, &c. be any variable angle = θ , the corresponding absciss x , and make $D F = p$ one fourth of the parameter. Then

$$(p + x) \cos \theta = p - x,$$

whence

$$x = \frac{1 - \cos \theta}{1 + \cos \theta} p.$$

And as the angle θ depends upon the angle formed between the axis of the reflector, and a line drawn from it to the eye, we are enabled to ascertain the ratio in which the illuminating power increases and diminishes, when the reflector makes a revolution in a given time.

The following Table shows the illuminating power of the reflector and lens at the end of every second of time during the passage of the light. The reflectors with ARGAND lamps being supposed to be placed on three sides, and revolving in 8 minutes, that with the lime ball and the lens having eight sides, and revolving in 21 minutes 20 seconds, making the time from the appearance to the re-appearance of the light in each 160 seconds. The illuminating powers are expressed in ARGAND lamps as placed in reflectors 21 inches diameter.

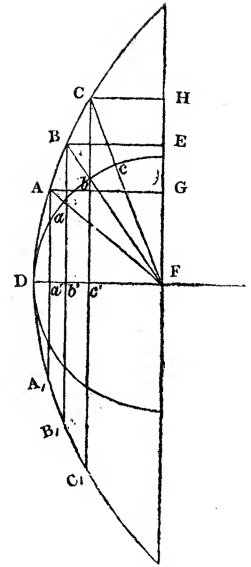

Seconds of Time.	3 Sides.	3 Sides.	8 Sides.	8 Sides.
	Single Reflector with ARGAND Lamp.	Ten Reflectors with ARGAND Lamp.	Single Reflector with Lime Ball.	French Lens.
1	·0285	·285	7·72	?
2	·0617	·617	16·51	?
3	·1019	1·019	27·33	10·4
4	·1501	1·501	40·66	10·4
5	·2133	2·133	57·48	10·4
6	·2937	2·937	79·35	10·4
7	·4019	4·019	108·98	10·4
8	·5555	5·555	151·35	10·4
9	·7905	7·905	216·98	10·4
10	1·0000	10·000	264·00	10·4
11	1·0000	10·000	264·00	10·4
12	1·0000	10·000	264·00	10·4
13	1·0000	10·000	264·00	10·4
14	1·0000	10·000	264·00	10·4
15	1·0000	10·000	264·00	10·4
16	1·0000	10·000	264·00	10·4
17	·7905	7·905	216·98	10·4
18	·5555	5·555	151·35	?
19	·4019	4·019	108·98	?
20	·2937	2·937	79·35	Dark.
21	·2133	2·133	57·48	—
22	·1501	1·501	40·66	—
23	·1019	1·019	27·33	—
24	·0617	·617	16·51	—
25	·0285	·285	7·72	—
26	Dark.	Dark.	Dark.	—

From the above Table it will be seen, that taking the full power of a reflector in connection with the duration due to its maximum divergence, gives a very inadequate idea of the quality of the instrument; and that from the high ratios in which the illuminating power increases and diminishes immediately before and after the brightest period, the duration due to the minimum divergence is all we can depend on, if the distance and state of the weather be such as to require the full power of the instrument; and as it is under circumstances like these that our beacon lights are most called for to give their aid to the benighted mariner, the duration of the brightest period becomes one of the most essential qualities to be attended to.

In comparing the lenses with the reflectors in this respect, we find (by referring to the above Table) that when the revolution is made so that the time from the appearance to the re-appearance of the light is equal in each, the duration of the brightest period is as 14 to 6, that is to say, the number of degrees of the horizon illuminated with the brightest light by the eight sides of a system of lenses, is to the number illuminated with the brightest light by the three sides of a reflector frame as 14 is to 6. Consequently we should require seven sides to our reflector frame to be equal in this respect to the lenses; and as each side must have ten reflectors to be equal in power to the lens with its additional apparatus, we should require to consume the oil of seventy ARGAND lamps to produce the same effect with the present construction of our reflectors, as that which is obtained in the lenses with the consumption of fifteen or sixteen ARGAND lamps.

Before, however, we give an opinion as to whether the lens or the reflectors is the best instrument for our lighthouses, or before we examine whether any improvement can be made in them, we must first consider the situation and purposes of the lighthouses to which they are to be applied.

On the Situations and Purposes of Lighthouses, and the Application of Lenses and Reflectors to the Duties required in them.

Lighthouses may be divided into three classes, viz.

First. Beacon or warning lights, being those which are placed to warn a vessel, and to which she can never be nearer than three or four miles.

Secondly. Guiding or leading lights, being those which are placed to guide a vessel, and to which she may approach very closely.

Thirdly. Lights which have both these duties to perform, being those which are placed to warn a vessel from a danger at a considerable distance in one direction, while they may be approached with safety in another.

In the first we require great illuminating power and a long duration of the brightest period, with a small angle of vertical divergence. In the second less illuminating power is required, but a large angle of vertical divergence, the duration of the extreme brightness not being of so much importance. In the third we require great

illuminating power, a long duration of the brightest period, and a large angle of vertical divergence.

The comparative qualities of the French system of lenses, and a first class light with reflectors, such as that at Beechy Head, as to their application to the above duties, will be seen in the following statement.

	First Class light with ten Reflectors on a side 21 in. diameter.	French Lens with its additional apparatus.
Oil consumed in $3\frac{1}{4}$ hours	4 qts. 1 pt.	2 qts. $\frac{1}{2}$ pt.
Illuminating power without the instruments expressed in ARGAND lamps	} 30	10.4
Illuminating power with the instruments expressed in reflectors with ARGAND lamps		
Maximum horizontal divergence per side	18° 45'	5° 15'
Minimum horizontal divergence per side	4° 46'	4° 4'
Number of sides	3	8
Degrees of horizon illuminated	56° 15'	42° 0'
Degrees of horizon with the full power	14° 18'	32° 32'
Maximum vertical divergence	31° 54'	3° 0'

From the above it will be seen that for a beacon light, when not more than 3° of vertical divergence is required, the lens is far the cheapest and best instrument, on account of its greater power and longer duration of the brightest period, although the illuminating power without the instrument is obtained at a greater consumption of oil than in the ARGAND burners; and that the reflectors as at present constructed are best adapted for leading or guiding lights, where a very large angle of vertical divergence is required. But in all those situations where more than 3° of vertical divergence are wanted, the lens is inapplicable, and where less than 30° are required there would be a useless waste of light in the reflectors. Now this is undoubtedly by far the most numerous class of lighthouses, we shall therefore examine with what advantage an alteration may be effected in the vertical divergences of the above instruments; but as many circumstances, such as the accuracy with which the instrument is made and fixed, atmospheric refraction, and a little variation in the height of the flame of the lamp would all tend to render variable the range of the angle of vertical divergence, we shall not attempt to employ very great exactness in this respect.

Considering these circumstances, the natural vertical divergence of the lens is the least that ought to be employed in any situation; and as the height of the flame which oil is capable of supporting to burn with advantage is nearly the same whatever may be the dimension of the lamp, the only way in which this divergence can be increased is by shortening the focal distance, to do which we must either reduce the area of each lens or the number of sides; the one would produce a loss of illuminating power, and in the others the figure of the instrument would become more distorted, and the greater obliquity with which the rays would strike and leave the lens would also be a cause of loss of light. Gas might perhaps be applied here with advantage, for by

having five or six concentric burners the same intensity of light might be obtained, while the greater height of the flame would give a greater vertical diverging angle.

But in the reflector where the vertical divergence admits of so much reduction, we are enabled to increase the focal distance, and consequently to employ a large reflector, by which means a considerable saving would be effected in the consumption of oil, or using the same oil, we might obtain a much greater illuminating power. If, for example, we employed a reflector 42 inches diameter, with six inches focal distance, the illuminating power depending on the area of the end would be equal to four of the usual reflectors, but the divergences would all be reduced one half, we should consequently require six sides instead of three to illuminate the same number of degrees in the horizon, so that by reducing the vertical divergence to 15° we obtain the same illuminating power with half the consumption of oil. Instead, however, of employing twice as many reflectors to produce the same durations, we might double the diameters of the lamps and use the same number as at present.

Before proceeding further with this part of the subject, it will be necessary to say a few words regarding the consumption of oil to produce a given illuminating power in lamps of different sizes and constructions. In the French lamp the consumption of oil to produce the same illuminating power as the ARGAND burners is nearly as $1\frac{1}{2}$ to 1, but here there are four concentric wicks, the largest of which is not more than three inches in diameter, and there would in consequence be a great intensity of heat, which would cause a considerable portion of the oil to pass off in vapour; but by increasing the diameter of a single wick, the intensity of heat would not be increased, we may therefore consider that the consumption would be exactly as the illuminating power. I am not aware of any experiments having been made to ascertain the consumption in lamps of two and three wicks, and it would perhaps be found to vary a little with their dimensions, but as we find the illuminating power to be obtained at 1 to 1 in the ARGAND lamp which has one wick, and as $1\frac{1}{2}$ to 1 in the French lamp which has four, it will be sufficiently near for our purpose to assume that the consumption of oil to produce a given illuminating power will be as follows:

In a lamp with one wick as 1 to 1.

In a lamp with two concentric wicks as $1\frac{1}{4}$ to 1.

In a lamp with three concentric wicks as $1\frac{1}{3}$ to 1.

In a lamp with four concentric wicks as $1\frac{1}{2}$ to 1.

And as we find that a lamp with one wick has an intensity of 1, and that the French lamp which has four wicks has an intensity of 4, it appears that the intensity increases directly as the number of wicks.

Calculating then as above, we should evidently obtain the illuminating power of ten reflectors at the cheapest rate, by employing a reflector the area of whose end should be equal to ten, with a lamp having only one wick; but as this would lead to such unwieldy instruments, it would doubtless be preferable to diminish the size of the apparatus by increasing the intensity of the lamps, and if it be within practicable

limits to make reflectors four feet in diameter, and seven inches focal distance, we might by employing three such reflectors with lamps $2\frac{1}{4}$ inches in diameter, having two concentric wicks, produce the same illuminating power and the same durations as the Beechy Head lighthouse, the vertical divergence being 14° , and the consumption equal to about seventeen or eighteen ARGAND burners.

Still, however, there would be only $14^\circ 14'$ of the horizon illuminated with the brightest light, but an improvement may be made in this respect by altering the form of the reflector, for as all reflectors of the same diameter have the same illuminating power when illuminated with the same lamp, that which has the greatest angle of minimum divergence, or the longest duration of the bright period, will be that in

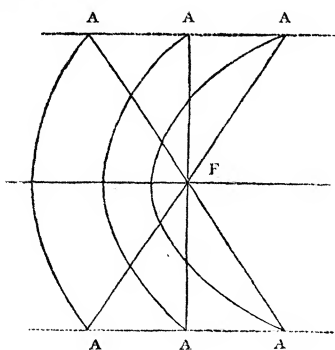

which the distance $A F$ is the shortest, that is to say when the focus is in the plane of the end of the reflector, and it is not improbable that having by this means less reflecting surface there would be less absorption and a better light. But in increasing the duration of the brightest period we diminish the angles of maximum divergence both horizontally and vertically. The divergences of a reflector four feet diameter and 7 inches focal distance with a lamp $2\frac{1}{4}$ inches diameter would be,

Vert. Div.
 $15^\circ 22'$

Max. Hor. Div.
 $18^\circ 34'$

Min. Hor. Div.
 $4^\circ 42'$

whereas if the focus were in the plane of its end they would be

Vert. Div.
 $8^\circ 22'$

Max. Hor. Div.
 $10^\circ 46'$

Min. Hor. Div.
 $5^\circ 22'$

But notwithstanding the great reduction in the angles of maximum divergence, I have no hesitation in considering this to be the best form of reflector when the vertical divergence required by the situation of the lighthouse will admit of its application, as it gives the longest duration to the bright period; for if the distance and state of the weather be such that it becomes a question whether the light be seen or not, the spread of weaker light will of course be invisible, and if the light be seen distinctly this weak light is not required, the regular appearance and disappearance of the light at known intervals being all that is necessary; such light, however, ought not to be used for purposes of distinction, as its duration is subject to great variations from distance or the state of the weather.

What number of degrees in the horizon it is necessary to illuminate, and more particularly what number it is necessary to illuminate with the brightest light, is a question upon which no determination appears to have been arrived at, but there can be no doubt in applying a given illuminating power (say that of ten reflectors 21 inches diameter,) to a lighthouse, that having attained a sufficient vertical divergence for its situation, the rest of the light cannot be better employed than in increasing as

much as possible the length of the period during which the full power of the instrument is acting, or the number of degrees in the horizon illuminated with the full power of the instrument, however much the spread of weaker light may be diminished by so doing.

From the foregoing it would appear that the best mode of applying lenses and reflectors to lighthouses when illuminated with oil is as follows.

When less than 3° of vertical divergence is required.

The French lens is to be preferred with its additional apparatus by which 32° 82' of the horizon is illuminated with a light equal to 10·4 reflectors 21 inches diameter, the sum of the angles of maximum horizontal divergence being 42° 0', and the consumption of oil equal to fifteen or sixteen ARGAND burners.

For more than 3° and less than 8° vertical divergence.

Reflectors four feet diameter should be employed, if practicable, with the focus in the plane of the end. Four such reflectors with lamps 2¼ inches diameter having two concentric wicks would illuminate 21° 28' of the horizon, with a light equal in power to 10·4 reflectors 21 inches diameter, the sum of the angles of maximum horizontal divergence being 43° 4', and the probable consumption equal to twenty-three ARGAND burners.

Or three such reflectors with lamps 2½ inches diameter having three concentric wicks would illuminate 17° 54' of the horizon, with a light equal in power to fifteen reflectors 21 inches diameter, the sum of the angles of maximum horizontal divergence being 35° 54', and the probable consumption equal to thirty ARGAND burners.

For more than 8° and less than 15° vertical divergence.

Reflectors four feet in diameter may be employed with the focal distance so arranged as to give the vertical divergence required.

And for more than 15° vertical divergence it will perhaps be found better to use smaller reflectors and more in number. This last, however, is a case which will rarely occur in lights where great illuminating power is required.

It is proper, however, to observe generally, that the lens is liable to one practical objection, viz. that depending on one light only, any accident whereby it becomes extinguished leads to total darkness, which is not so likely to happen in a system of reflectors which has several lights to depend on.

P.S. Since writing the above, it has occurred to me that a considerable increase of illuminating power would be obtained in a reflector whose focus was in the plane of its end by the application of a spherical reflector (as in the annexed figure) to intercept the rays which would otherwise be lost, and thus to return them through the light itself, and thereby increase its intensity.

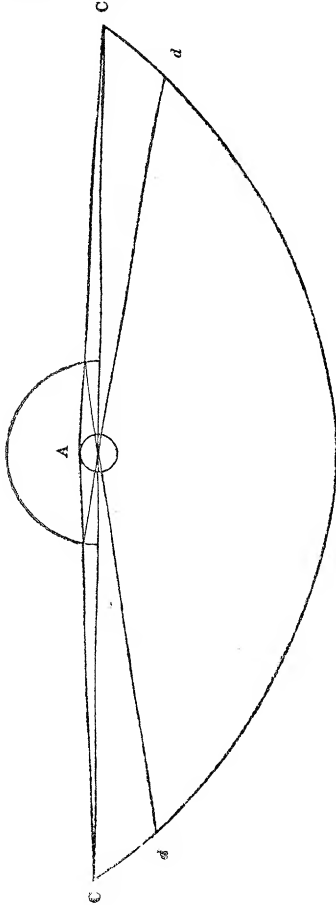

The spherical reflector ought to be made about one fifth of the diameter of the parabolic reflector, and a little less than a semisphere, so as just to be without the lines A C. Here it will be seen that the light upon the part *dd* will be doubled through all its divergences, minus the absorption of light in the spherical reflector, and the area of light obstructed by it. If the spherical reflector were made of glass silvered (in which I find from experiment, that the absorption of light is about two fifths,) the increase of illuminating power obtained by this means in the parabolic reflector would be about one third or one fourth.

The effect of a coloured light might also probably be produced by a similar segment of coloured glass between the lamp and reflector.